

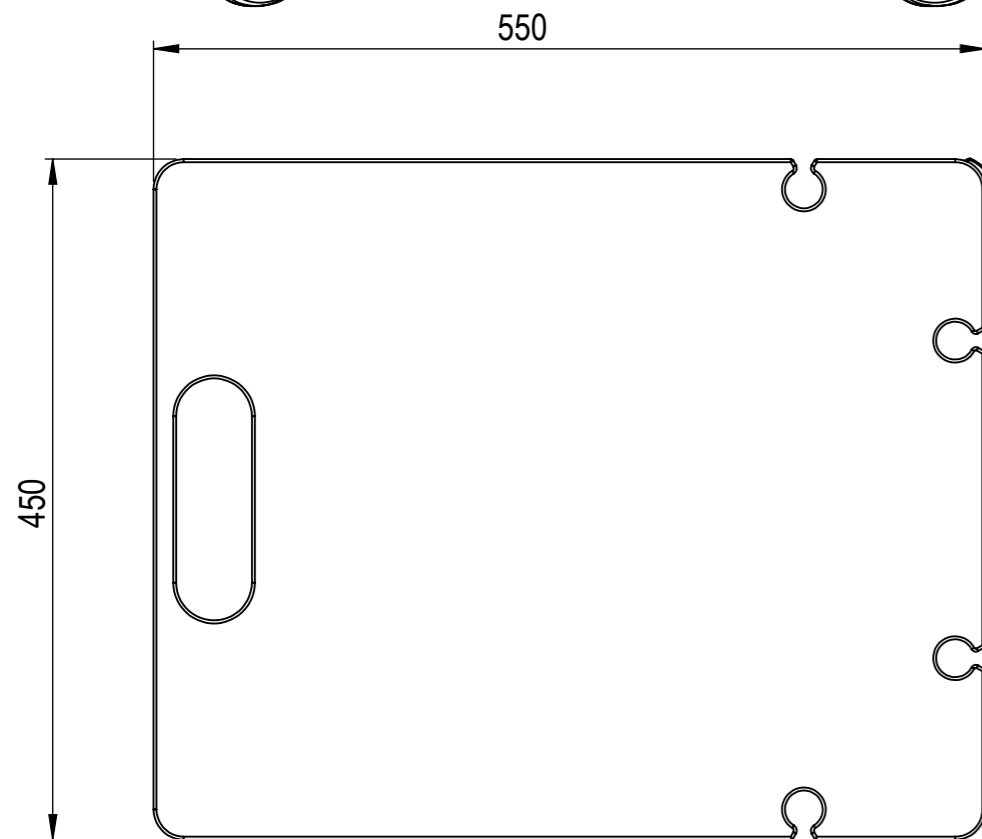

ITEM NO.	PART NUMBER	Description	QTY.
1	DRP-610	Hjulplade med stifter	1
2	DL14	Løfte søjle 3-delt	1
3	DRP-519	Bordplade EPJ	1
4	FS3-smal	Betjening	1
5	BA001	Batteri	1
6	cbd6s	Styring	1
7	DRP-520	Topbeslag for bord	1
8	5325 PJP 075 L51-10	Hjul med bremse ø75	4
9	DIN 912 M4 x 6 --- 6N		2
10	DIN 912 M5 x 35 --- 22N		2

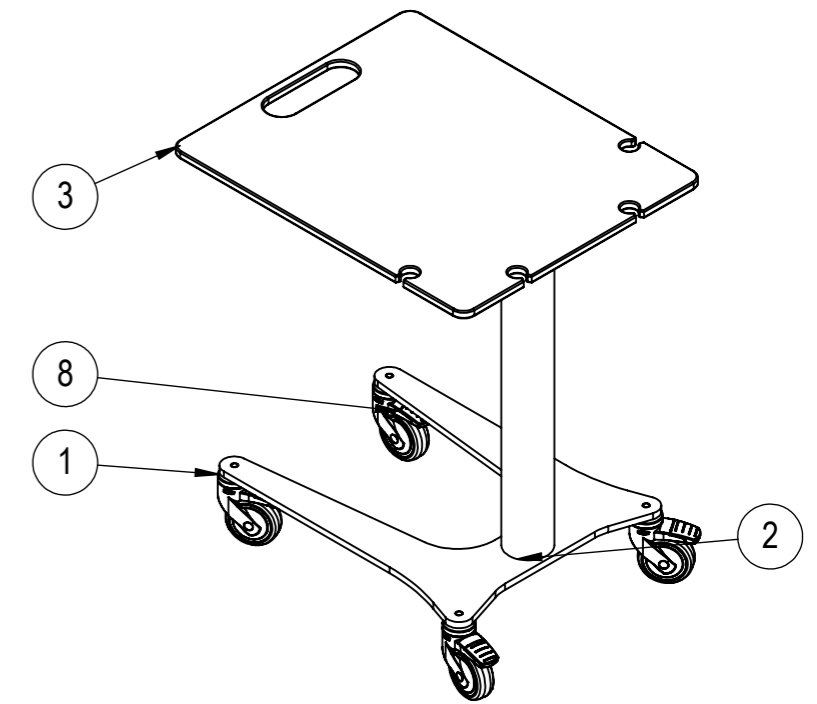
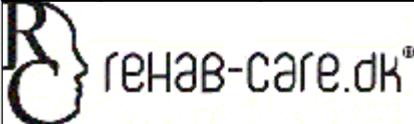

ø75 bremsehjul

Rev	Date	Note
A		
		
Avnvej 10 -7400-Herring Denmark WWW.rehab-care.dk		Scale: 1:5 Paper: A3 Sheet 1 of 1
Description: EPJ bord med motor 550x450		
Surface treatment:		Color:
Drawn By: MG	Drawn Date: 08-01-20	
Weight: 18566.56	State: - ok	Material:
 Tolerances ISO 2768-mK		Drawing No.: DRP-650
		Rev. A